



Distribution Transformer

1500/1725kVA 13.8kV/480V
ONAN/ONAF

www.hctr.co.kr

HAN CHANG

1500/1725kVA 13.8kV/480V ONAN/ONAF
DISTRIBUTION TRANSFORMER

SPECIFICATION

Service area	Outdoor
Applicable standard	ANSI C57.12.00
Final paint color	Gray ANSI 61
Insulating oil	MINERAL
Rated capacity	1500 / 1725 kVA
Phase/Rated frequency	3 / 60
Rated voltage HV/LV	13.8 kV / 480 V
Tap voltage	±5% with 2.5% steps
Tap changing method	No load
Connection or polarity	Dyn11
Cooling method	ONAN/ONAF
Sound level	58 dB



Features

Removable Radoators
Strength Tank
Best Design for all fact
Minimize current loss

HAN CHANG

1500/1725kVA 13.8kV/480V ONAN/ONAF DISTRIBUTION TRANSFORMER

SIZE

Length	2360 mm
Width	2330 mm
Height	1780 mm

WEIGHT

Oil	980 liter
Tank	3400 kG
Total	7167 kG

IN TANK

OUT LINE

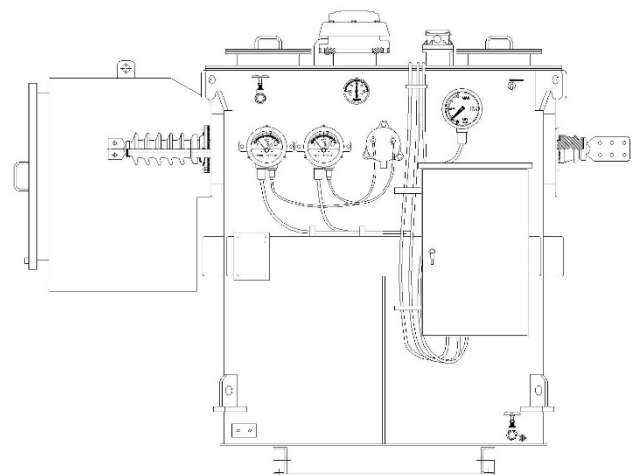
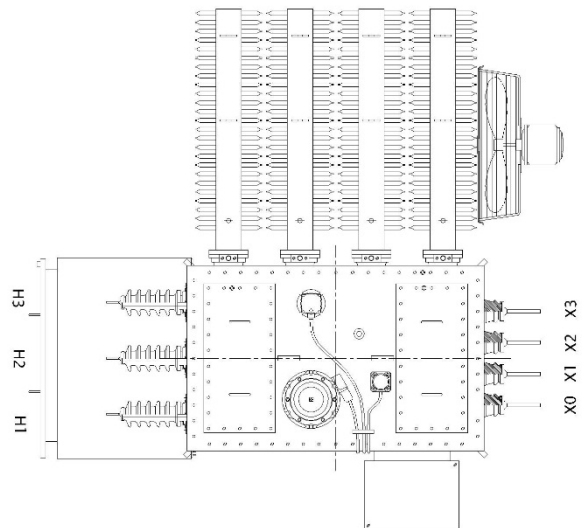

COIL & CORE

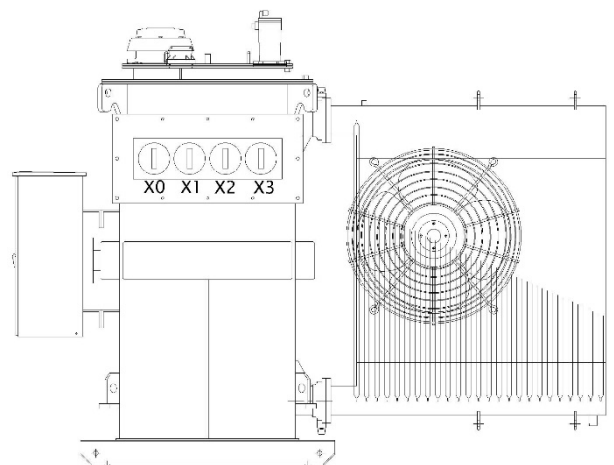
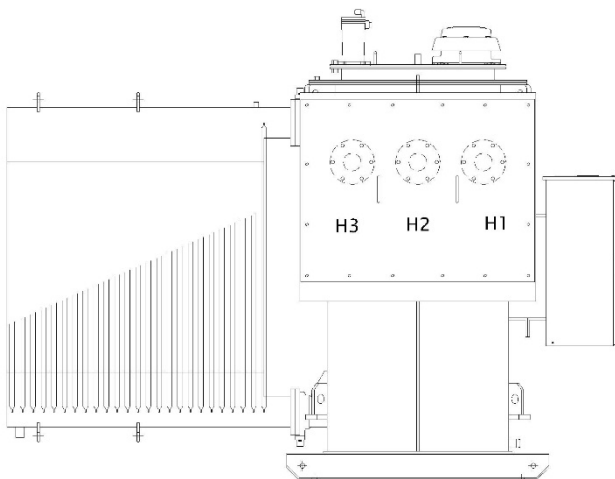

INQUIRY

Sales@hctr.co.kr

Michael@transformerprice.com

Taeyoung@hctr.co.kr

The logo for IEV, consisting of the letters 'IEV' in a bold, blue, sans-serif font. The 'V' has a stylized orange and blue swoosh extending from its top right corner.

Republic of Korea
1593-3 Songjung-dong,
Ganseo-gu, Busan

Phone: +82 51 831 3470

Fax: +82 51 831 3477

www.hctr.co.kr

© 2013 Hanchang Transformer co.,ltd. All rights reserved. The information in this publication is provided without any express or implied representation or warranty in relation to any contract which may be entered into. Hanchang shall not be responsible for any loss or damage of whatsoever nature [including consequential loss or damage] suffered or incurred, directly or indirectly, by the reader or any other person as a result of relying on the information contained in this publication.



Quality
ISO 9001
ISO 14001