

1MVA, 1.5MVA

22kV-433V

TRANSFORMER

By IEC & NEMA

www.hctr.co.kr

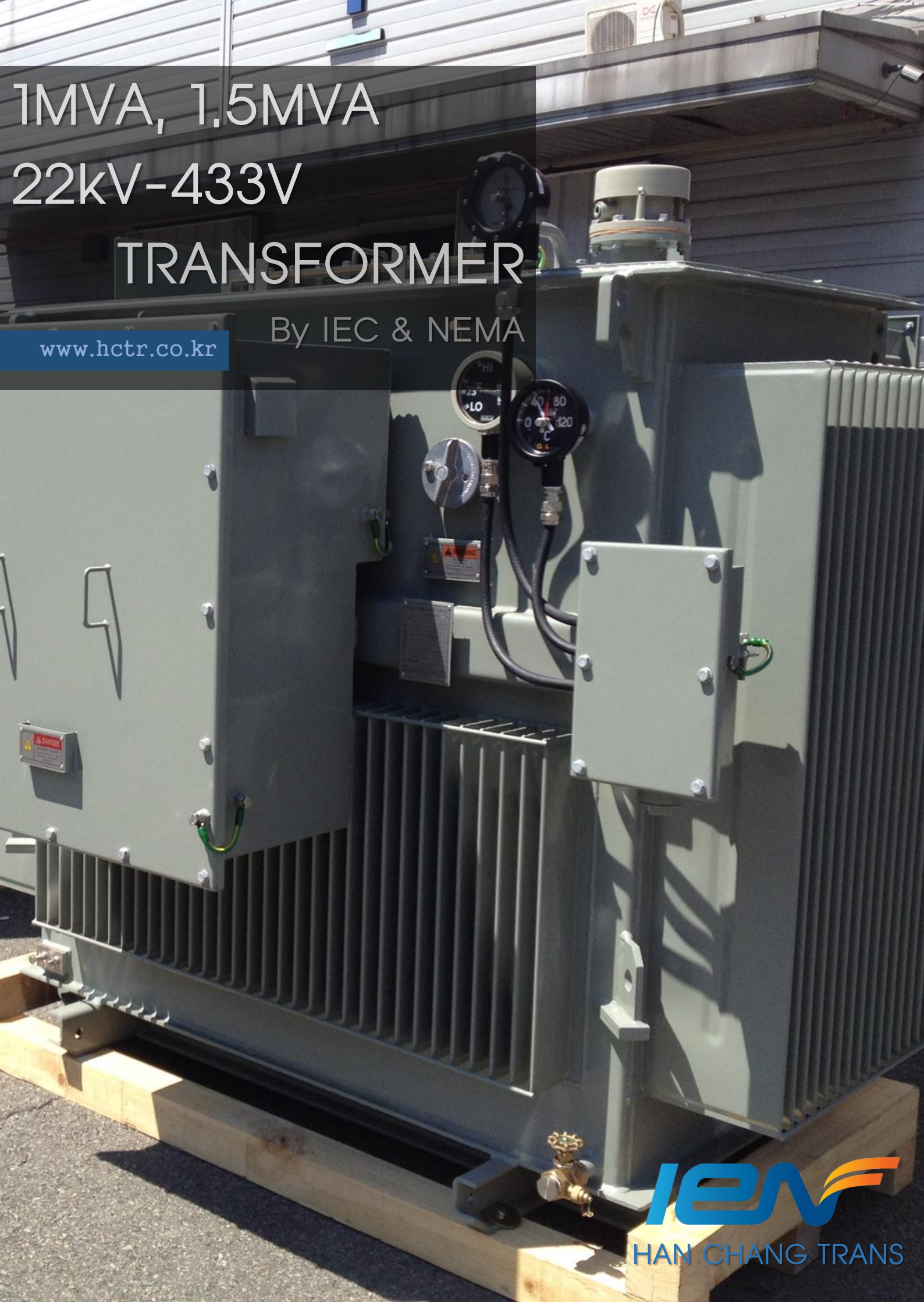

HAN CHANG

1000kVA, 22000V DELTA – 433V YWE DISTRIBUTION TRANSFORMER

SPECIFICATION

Applicable standard	IEC 60296
Final paint color	RAL 7033
Insulating oil	Mineral
Rated capacity	1000 kVA (winding temp rise 65°C)
Phase/Rated frequency	3P / 50Hz
Rated voltage H.V	22000V DELTA
Rated voltage L.V	433V WYE
Tap voltage	5 TAPS ($\pm 5 \times 2.5\%$)
Tap changing method	NLTC
Connection or polarity	Dyn11
Cooling method	ONAN
Sound level	55 dB
Efficiency	99.4%

SIZE

Length	1900 mm
Width	1750 mm
Height	1800 mm

WEIGHT

Core&Coil	3410 kg
Tank	1201 kg
Oil	989 kg
Total	5600 kg

CORE & COIL



HAN CHANG

1000kVA, 22000V DELTA – 433V YWE DISTRIBUTION TRANSFORMER

OUT LINE

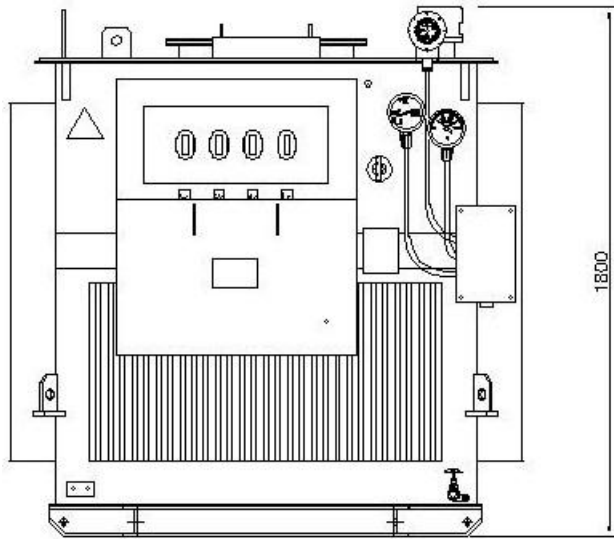

Front view

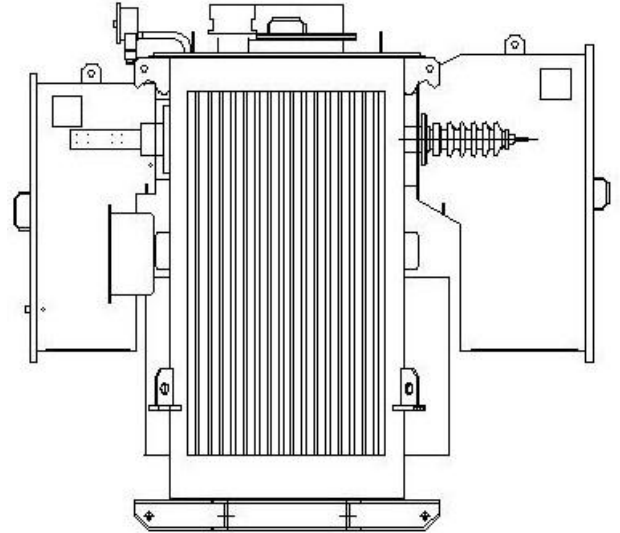

Side view

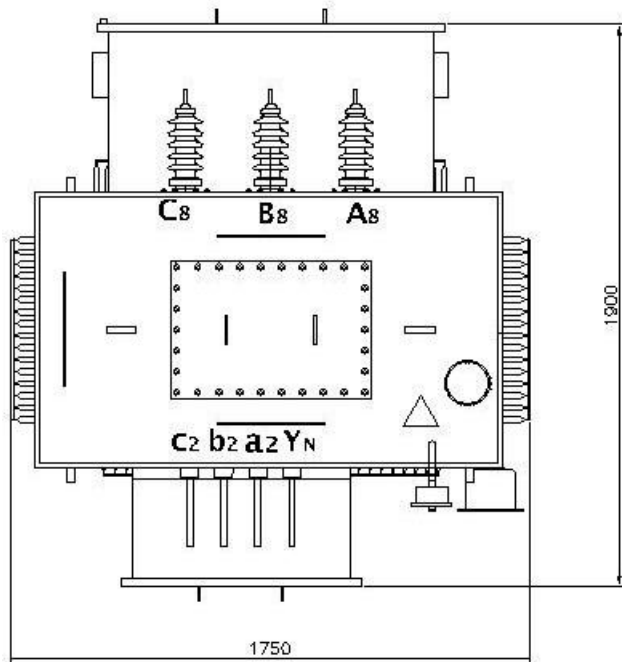

Top view

PRODUCT VIEW



HAN CHANG

1500kVA, 22000V DELTA – 433V WYE DISTRIBUTION TRANSFORMER

SPECIFICATION

Applicable standard	IEC 60296
Final paint color	RAL 7033
Insulating oil	Mineral
Rated capacity	1500 kVA (winding temp rise 65°C)
Phase/Rated frequency	3P / 50Hz
Rated voltage H.V	22000V DELTA
Rated voltage L.V	433V WYE
Tap voltage	5 TAPS ($\pm 5 \times 2.5\%$)
Tap changing method	NLTC
Connection or polarity	Dyn11
Cooling method	ONAN
Sound level	55 dB
Efficiency	99.4%

SIZE

Length	2100 mm
Width	2000 mm
Height	1800 mm

WEIGHT

Core&Coil	3670 kg
Tank	1100 kg
Oil	1150 kg
Total	5920 kg

CORE & COIL



HAN CHANG

1500kVA, 22000V DELTA – 433V YWE DISTRIBUTION TRANSFORMER

OUT LINE

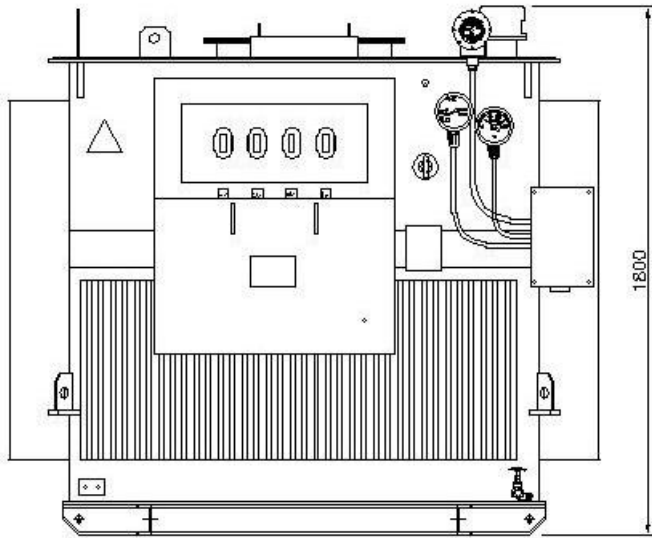

Front view

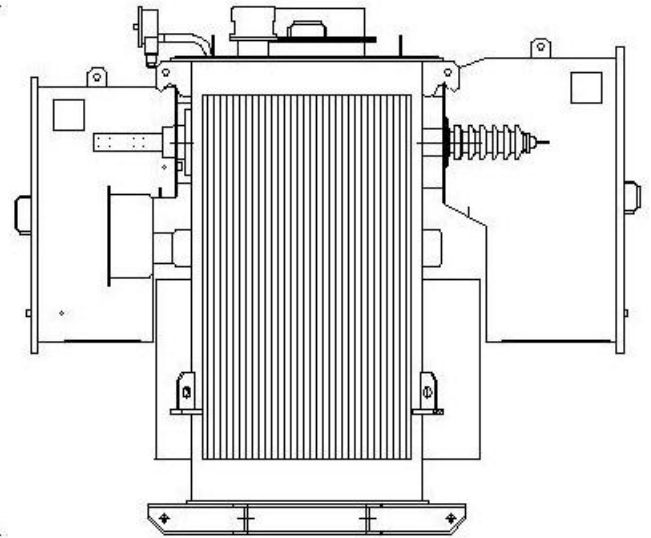

Side view

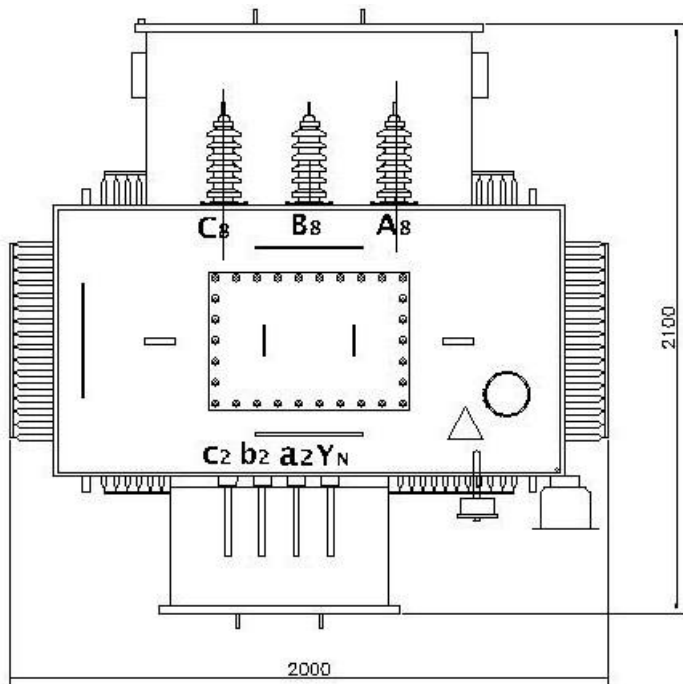

Top view

PRODUCT VIEW



HAN CHANG

Schedule of product particulars
DISTRIBUTION TRANSFORMER

A PART LIST for 1MVA & 1.5MVA

No.	Part name	Manufacturer	Country of Origin
1	HV bushing Well	TAESUNG	KOREA
2	Hv bushing Insert	TCT	KOREA
3	LV bushing	WONIL	KOREA
4	Tap Changer	WEBSTER WILKINSON	ENGLAND
5	Pressure Relief Device	TAIJIN	KOREA
6	Core Steel	POSCO	KOREA
7	Oil Temperature Gauge	TAIJIN	KOREA
8	Oil Level Gauge	TAIJIN	KOREA
9	Transformer Oil	S-OIL	KOREA
10	Pressure relief Device	TAIJIN	KOREA
11	Tank	HANCHANG	KOREA
12	Gas sampling Valve	HEARTLAND	USA
13	Radiator	HANCHANG	KOREA

INQUIRY

Sales@hctr.co.kr

Michael@transformerprice.com

Taeyoung@hctr.co.kr



Republic of Korea

1593-3 Songjung-dong,

Ganseong-gu, Busan

Phone: +82 51 831 3470

Fax: +82 51 831 3477

www.hctr.co.kr

© 2013 Hanchang Transformer co.,ltd. All rights reserved. The information in this publication is provided without any express or implied representation or warranty in relation to any contract which may be entered into. Hanchang shall not be responsible for any loss or damage of whatsoever nature [including consequential loss or damage] suffered or incurred, directly or indirectly, by the reader or any other person as a result of relying on the information contained in this publication.



Quality
ISO 9001
ISO 14001

TRANSFORMERPRICE.COM-KR