



Han Chang
Transformer

Pad-mounted Transformer

2500kVA 12kV/480V ONAN

www.hctr.co.kr

HAN CHANG

2500kVA 12kV/480V ONAN
PAD-MOUNTED TRANSFORMER

SPECIFICATION

Service area	Outdoor
Applicable standard	IEC 60076
Final paint color	Munsell No.5Y 7/1
Insulating oil	Mineral
Rated capacity	2500 kVA
Phase/Rated frequency	3 / 60
Rated voltage HV/LV	12 kV / 480 V
Tap voltage	HV : 33kV \pm 8 x 1.25%
Tap changing method	OLTC
Connection or polarity	Dyn1
Cooling method	ONAN/ONAF
Sound level	73 / 74 dB



Features

Removable Radoators
Strength Tank
Best Design for all fact
Minimize current loss

HAN CHANG

2500kVA 12kV/480V ONAN PAD-MOUNTED TRANSFORMER

SIZE

Length	7100 mm
Width	5700 mm
Height	5000 mm

WEIGHT

Oil	1779 liter
Tank	5566 kG
Total	7167 kG

IN TANK



OUT LINE

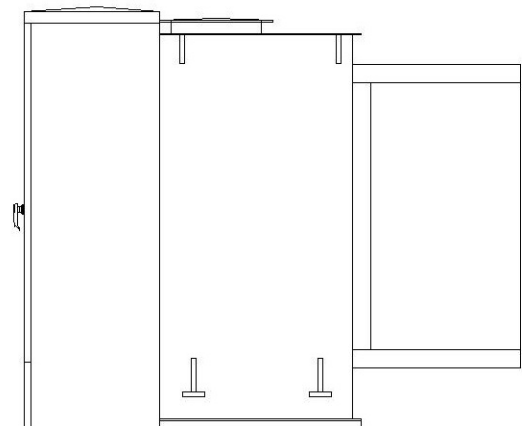
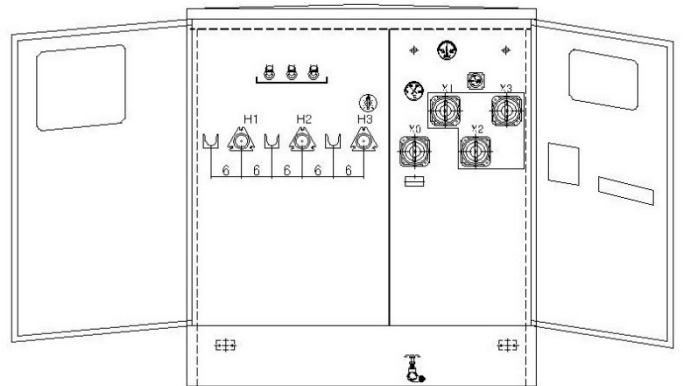
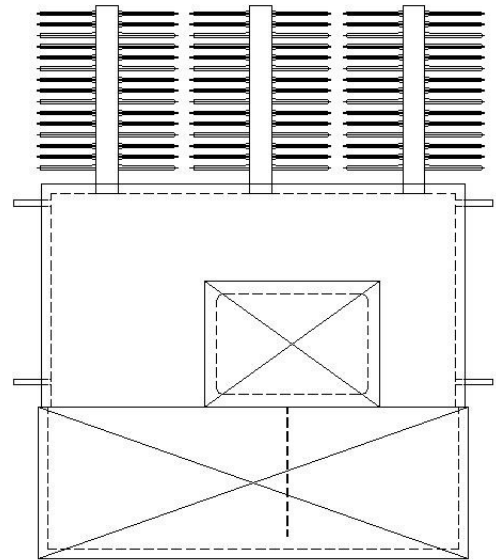

INQUIRY

Sales@hctr.co.kr

Michael@transformerprice.com

Taeyoung@hctr.co.kr

The logo for IEV, consisting of the letters 'IEV' in a bold, blue, sans-serif font. The 'V' has a stylized orange and blue swoosh extending from its top right corner.

Republic of Korea
1593-3 Songjung-dong,
Ganseo-gu, Busan

Phone: +82 51 831 3470

Fax: +82 51 831 3477

www.hctr.co.kr

© 2013 Hanchang Transformer co.,ltd. All rights reserved. The information in this publication is provided without any express or implied representation or warranty in relation to any contract which may be entered into. Hanchang shall not be responsible for any loss or damage of whatsoever nature [including consequential loss or damage] suffered or incurred, directly or indirectly, by the reader or any other person as a result of relying on the information contained in this publication.



Quality
ISO 9001
ISO 14001