

2500kVA, 22-11kV
500kVA, 1000-415V
Distribution Transformer
By IEC

www.hctr.co.kr

IEV
HAN CHANG TRANS

HAN CHANG TRANSFORMER

500kVA, 11000 Delta volts – 415 Star volts, DISTRIBUTION TRANSFORMER

Technical Specification

Applicable standard	IEC 60076
Final paint color	MUNSELL # 5Y-7/1
Insulating oil	Mineral Oil
Rated capacity	500 kVA (winding temp rise 55°C)
Phase/Rated frequency	3P / 50Hz
Rated voltage H.V	11000V Delta
Rated voltage L.V	415V Star
Tap voltage	3 TAPS (±5%)
Tap changing method	De-energized Tap Changer
Connection or polarity	YNyn0
Cooling method	ONAN
Efficiency	99.2%

Size

Length	1700 mm
Width	1700 mm
Height	1650 mm

Features

- ✓ Compact Design
- ✓ Nameplate per IEC Requirement
- ✓ Standard Accessory

Weight

Oil	630 liter
Total	2780 kg

HAN CHANG TRANSFORMER

**500kVA, 11000 Delta volts – 415 Star volts,
DISTRIBUTION TRANSFORMER**

OUT LINE

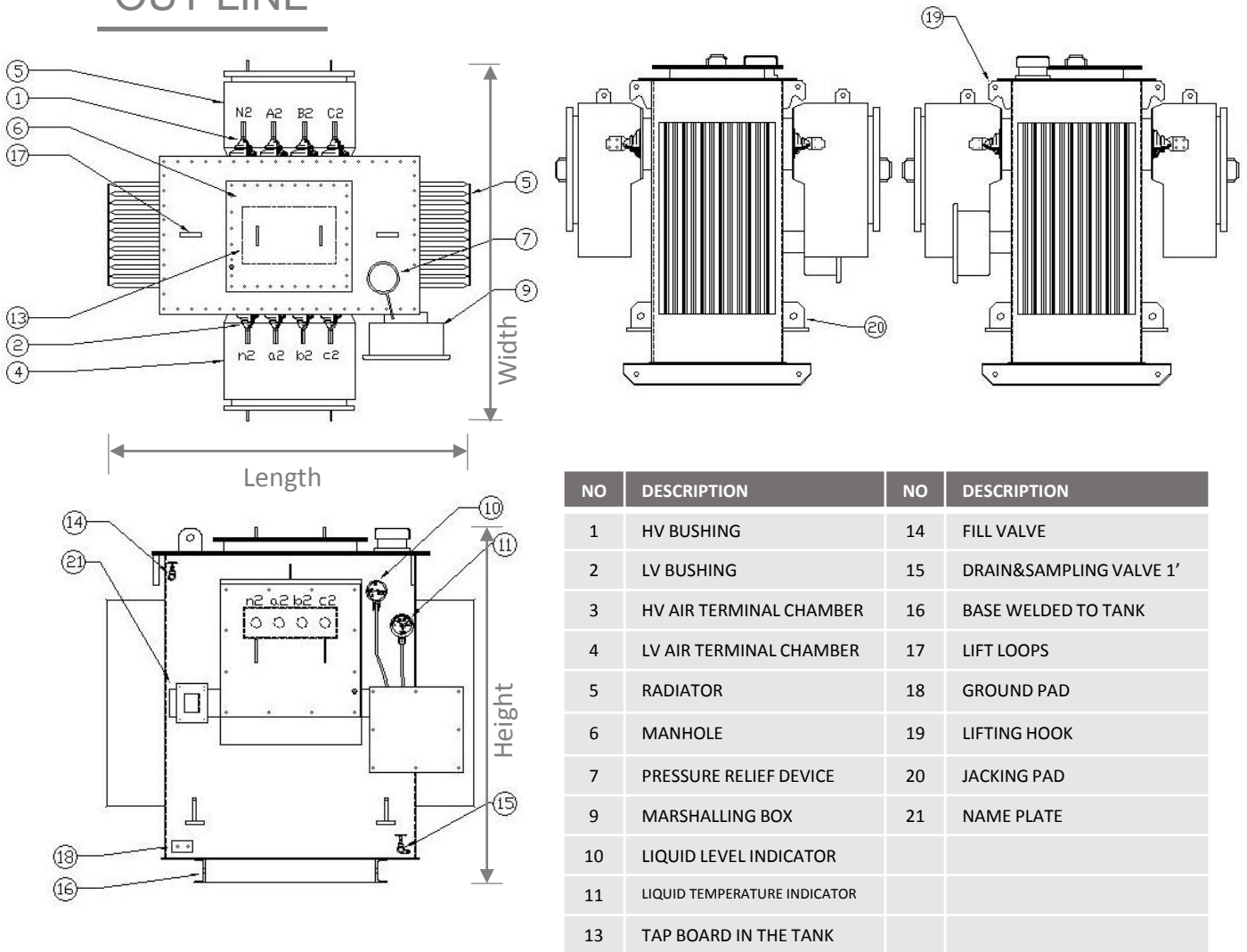

REFERENCE PHOTOS



HAN CHANG TRANSFORMER

2500kVA, 22000 Delta volts - 11000 Star volts, DISTRIBUTION TRANSFORMER

Technical Specification

Applicable standard	IEC 60076
Final paint color	MUNSELL # 5Y-7/1
Insulating oil	Mineral Oil
Rated capacity	2500 kVA (winding temp rise 55°C)
Phase/Rated frequency	3P / 50Hz
Rated voltage H.V	22000V Delta
Rated voltage L.V	11000V Star
Tap voltage	5 TAPS ($\pm 2.5\%$)
Tap changing method	De-energized Tap Changer
Connection or polarity	Dyn11
Cooling method	ONAN
Efficiency	99.49%

Size

Length	2200 mm
Width	2850 mm
Height	2100 mm

Weight

Oil	2340 liter
Total	8410 kg

Features

- ✓ Compact Design
- ✓ Nameplate per IEC Requirement
- ✓ Standard Accessory

HAN CHANG TRANSFORMER

2500kVA, 22000 Delta volts - 11000 Star volts, DISTRIBUTION TRANSFORMER

OUT LINE

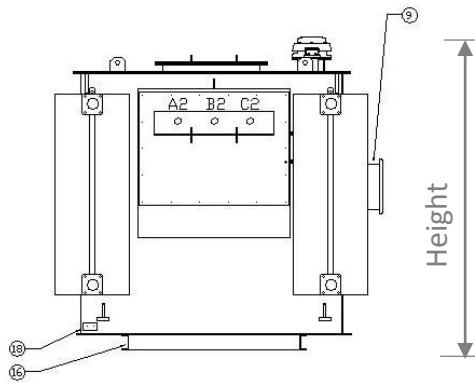
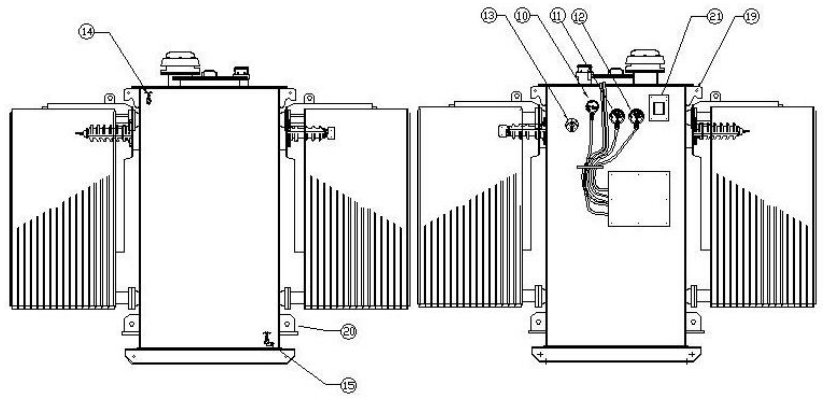
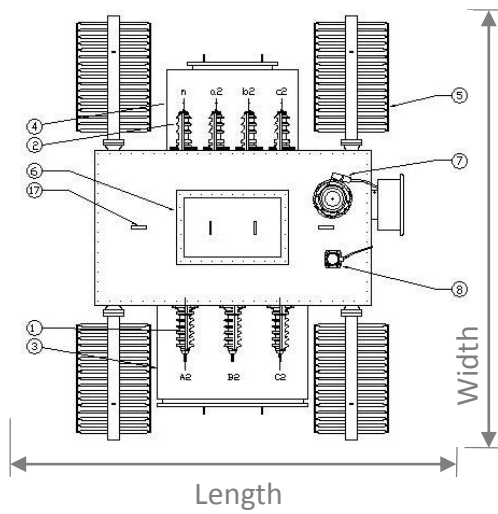

NO	DESCRIPTION	NO	DESCRIPTION
1	HV BUSHING	12	WINDING TEMPERATURE INDICATOR
2	LV BUSHING	13	TAP CHANGER
3	HV AIR TERMINAL CHAMBER	14	FILL VALVE
4	LV AIR TERMINAL CHAMBER	15	DRAIN&SAMPLING VALVE 1'
5	RADIATOR	16	BASE WELDED TO TANK
6	MANHOLE	17	LIFT LOOPS
7	PRESSURE RELIEF DEVICE	18	GROUND PAD
8	B.C.T BOX	19	LIFTING HOOK
9	MARSHALLING BOX	20	JACKING PAD
10	LIQUID LEVEL INDICATOR	21	NAME PLATE
11	LIQUID TEMPERATURE INDICATOR		

REFERENCE PHOTOS



INQUIRY

[Mr. Michael Jang](mailto:michael@transformerprice.com)
michael@transformerprice.com

[Mr. Taeyoung Kim](mailto:taeyoung@hctr.co.kr)
taeyoung@hctr.co.kr

[Ms. Monica Lyu](mailto:monica@hctr.co.kr)
monica@hctr.co.kr

1000V

DANGER
HIGH VOLTAGE

500kVA

Republic of Korea
1593-3 Songjung-dong,
Ganseo-gu, Busan
Phone: +82 51 831 3470
Fax: +82 51 831 3477
www.hctr.co.kr



© 2013 Hanchang Transformer co.,ltd. All rights reserved. The information in this publication is provided without any express or implied representation or warranty in relation to any contract which may be entered into. Hanchang shall not be responsible for any loss or damage of whatsoever nature [including consequential loss or damage] suffered or incurred, directly or indirectly, by the reader or any other person as a result of relying on the information contained in this publication.



Quality
ISO 9001
ISO 14001